

MANIFOLD CHAMBER W16

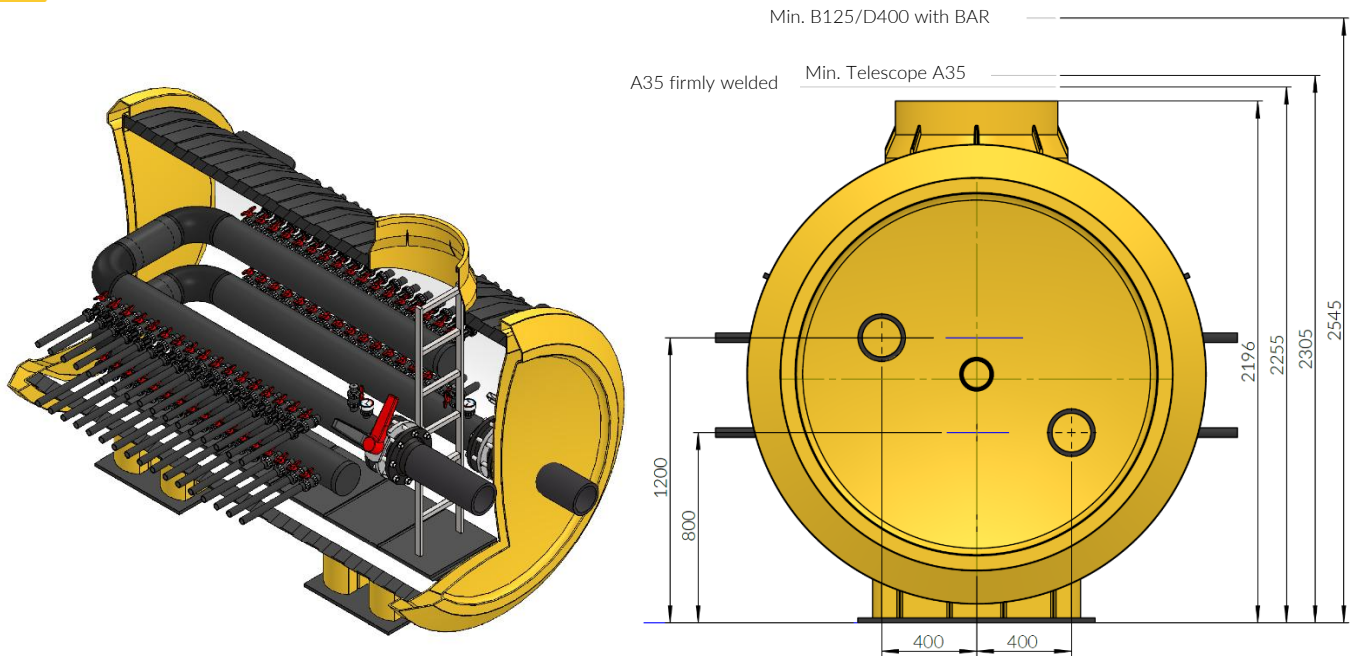

A geothermal manifold chamber for ground probes and ground-coupled heat exchangers, fully prefabricated and tested at the factory.

Freely configurable thanks to selectable connection orientations, pipe diameters and an extensive range of accessories.

The probe connections are routed through the chamber wall to the outside and are prepared for electrofusion sockets, ensuring quick, safe and permanently leak-proof installation.

Minimal Height [mm]	2.255
Maximal Length [mm]	12.000

TECHNICAL DATA

- Shaft body constructed from solid double-walled 100% polyethylene
- Suitable for lorries without a load-distributing plate
- Can be backfilled with permeable excavated material
- Groundwater-resistant up to the top of the tank
- Pressure-water-tight probe connections, factory-tested
- Manifold DA 100 - 250, PE100 RC pipe SDR 11 PN16, suitable for water mixtures containing standard corrosion and antifreeze additives
- 1" PVC ball valve for filling/venting
- Operating temperature: -20 to 40°C
- Operating pressure: up to 3 bar
- Test pressure: 12 bar
- Brine circuits with individual shut-off (PVC ball valve DN 25 with EPDM seals)
- Probe diameter DA 32, 40 (SDR 7.4) or 50 (SDR 11)
- Probe spacing 100 mm (130 or 150 mm on request)
- Flow meter DN25 in selectable measuring range variants
 - 4-12, 10-27, 15-40, 20-60, 28-82 l/min
- Connection to brine pump available with or without shut-off valve
- Water-tight cover – DN600, load classes A35, B125 or D400
- Buoyancy control must be provided by the client

NOTE

Installation, connection and commissioning must be carried out strictly in accordance with the manufacturer's current installation instructions!